

SOVIET GEOSTATIONARY OPERATIONAL METEOROLOGICAL SATELLITE GOMS:
CURRENT STATUS AND PERSPECTIVES FOR WIND DATA EXTRACTION

A. Karpov *

* Committee for Hydrometeorology of the USSR,
Pavlik Morozov Street, 123376, Moscow, USSR

ABSTRACT

Growing demands to have reliable information about the current and future state of the Earth and its atmosphere constitute a basis for the development of an integrated, international satellite system, comprising geostationary and near-polar orbiting satellites. Along with meteorological, oceanographic and earth - resources Soviet satellite systems known as "METEOR", "OKEAN" and "RESURS" series of satellites, national plans envisage the development of Geostationary Meteorological Satellite (GOMS) to be launched in 1991 and stationed over the Equator at 76° E. GOMS is designed as three-axis stabilized spacecraft and will have an active life - time of 2-3 years. The paper will review the major technical characteristics of GOMS and its missions which would provide an input to the World Weather Watch system of WMO.

BACKGROUND

Committee for Hydrometeorology of the USSR (GOSGIDROMET) is the national central agency providing relevant environmental and climate information to the public, various industrial organizations and decision-making bodies. GOSGIDROMET is also responsible for operating USSR environmental satellites which have been steadily growing as an essential component of the national observing system for last decades [2]. The purpose of the national space-based sub-system is to provide continuous observations of the state of atmosphere, land water and the World ocean, sea ice, underlying surface, agricultural crops, state of the Earth's electromagnetic radiation and to distribute relevant data and information to various domestic and foreign users.

The current satellite system which GOSGIDROMET operates directly includes:

- meteorological satellites of "METEOR-2" and "METEOR-3" type;
- oceanographic satellites of "OKEAN" type;
- operational land resources satellites of "RESURS" type;
- ground receiving, processing and distribution complex including Main and Regional centres in Moscow, Novosibirsk, Tashkent, Khabarovsk and more than 80 APT stations spread over the USSR territory.

National plans envisage the development and operation of an integrated meteorological satellite system in the 90-s comprising both low-orbit and geostationary satellites. With the launch of geostationary meteorological satellite in the nearest future, USSR would assure that data products and services would be

integral to the Global Observing System coordinated by the WMO and will join other satellite operators in their efforts to provide better observations of the Earth's environment.

GOMS AND ITS INSTRUMENT CHARACTERISTICS

The intention to build Soviet Geostationary Operational Meteorological Satellite (GOMS) has been indicated in the 70-s at the early CGMS (former Coordination of Geostationary Meteorological Satellites) meetings which have convened yearly to assess the status of the programs and plans for mutual compatibility. In conjunction with CGMS - XIX (Tashkent, USSR, 1990), an engineering and flight models of GOMS were shown to CGMS' members at the All-Union Research Institute of Electromechanics in Moscow [3]. Table 1 presents basic characteristics of GOMS.

TABLE 1. Basic characteristics of GOMS.

Spacecraft characteristics			
Satellite mass	- 2400 Kg		
Payload mass	- 800 Kg		
Stabilization	- 3-axis		
Power	- 1500 W (per day)		
Instrument configuration	- Combined VIS and IR imager, independent radiation / magnetometric system, data collection and relay complex		
Lifetime	- not less than 3 years		
Instrument	Spectral band	Coverage	Resolution, km
Scanning TV imager (8000 lines per frame)	0.46-0.7 mkm	Full disk	1.25
Scanning IR radiometer (1400 lines per frame)	10.5-12.5 mkm (6.0- 7.0mkm)	Full disk	6.5
Radio complex for data collection, transmission and relay		Main and Regional centres, DCP's, ART stations in the radio-visibility zone of s/c (75 N - 75 S)	
radiation/magnetometric monitoring complex	0.02-600 MeV 3.0 -8.0 KeV 100 -1300 A		

The GOMS imaging frequency is not less than 30 min with frame time of 15 minutes. As it is seen from the Table, on-board

instruments will provide continuous observations of the Earth's disk within 60 deg. with respect to the stationary point of 76° E over the Equator. Receiver / transponder complex will provide collection and relay of hydrometeorological data from DCP's, data exchange between major ground receiving centres including data from polar-orbiting satellites and end-products distribution to various users. Satellite communication links characteristics are summarized in Table 2.

Table 2. GOMS communication links characteristics

Radio channel	Frequency band	Data transmission rate	Designation
I,II	1685MHz,7465MHz	2.56 Mbps	Transmission of imagery and heliogeophysical information from s/c to RPC's
III	401-403 MHz	100 bps	Transmission of data from DCP's to s/c
IV,V	1697MHz,7482MHz	100 bps	Transmission of data from DCP's to RPC's via s/c
VI, VII	2115MHz, 8195MHz	1200 bps 100 bps	Transmission in WEFAX format and alphanumeric data from RPC's to s/c
VIII	1691 MHz	1200 bps 100 bps	Retransmission of WEFAX format and alphanumeric data from s/c to RPC's
IX	8190 MHz	0.96 Mbps	Transmission of high-speed digital data from RPC's to s/c
X	7465 MHz	0.96 Mbps	Transmission of high-speed digital data from s/c to RPC's
XI	469 MHz		Interrogation of DCP's from s/c
XII	2119 MHz		Transmission of DCP's request from RPC's to s/c

A general view of GOMS spacecraft is shown in Figure 1.

GOMS' MISSIONS, SERVICES AND PRODUCTS

The main mission of GOMS is to utilize the scanning visible and infrared radiometer to obtain the imagery of the Earth from a geostationary orbit for analysis of cloud distribution and other

SPACE SATELLITE GOMS

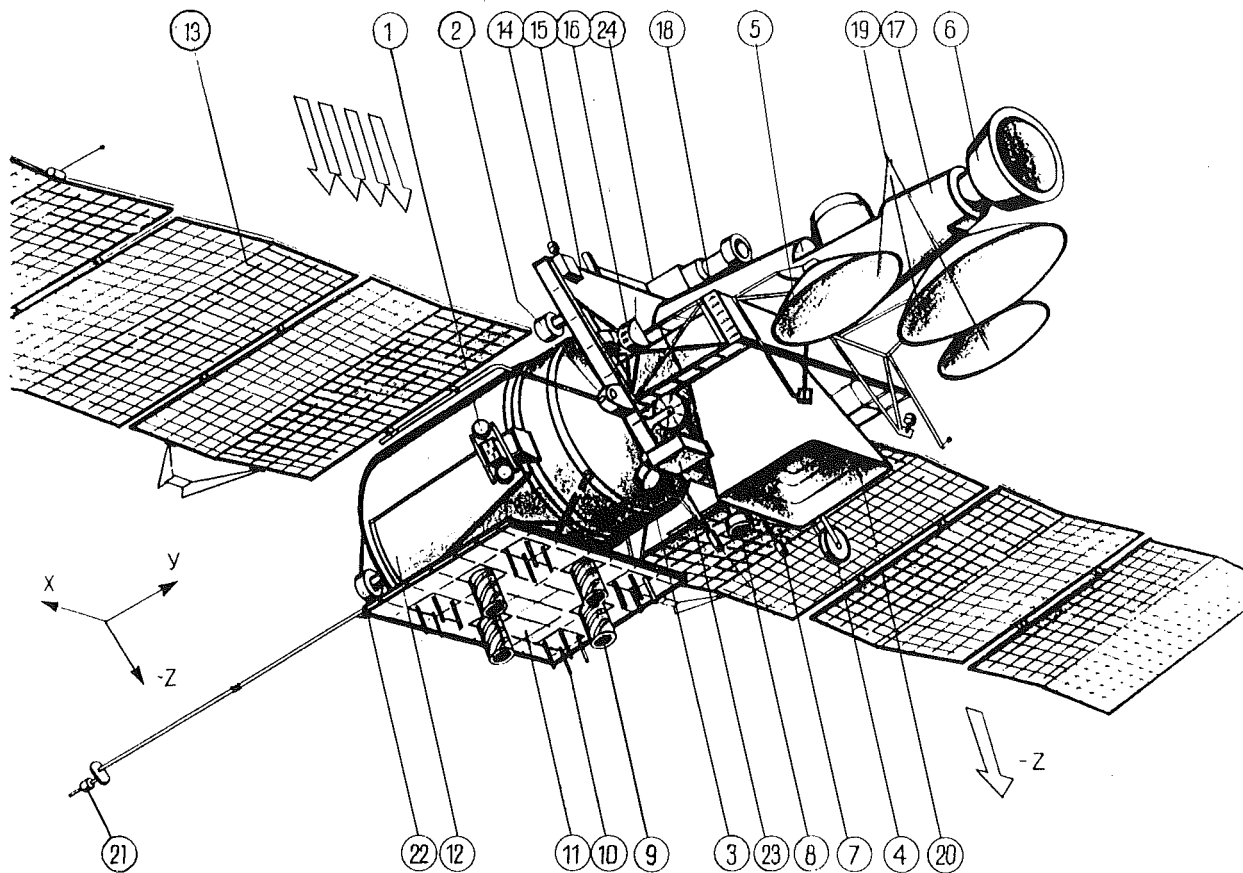

- | | |
|--|---|
| 1 Electric jet system (EJS) | 12 Hermetically sealed module |
| 2 Sun-angle sensor of the attitude control system | 13 Solar array |
| 3 Instrument platform | 14 UV sensor (sun UV radiometer SuVR) |
| 4 Flywheel engine of the attitude control system | 15 Coarse sun sensor |
| 5 Two-coordinate drive of the antenna-feeder system (AFS) | 16 X-ray sensor |
| 6 OTVS radiation cooler | 17 On-board TV system (OTVS) |
| 7 AFS of the command-measuring system (CMS) | 18 Polar star tracker (PST) |
| 8 Local vertical reference (LVR) | 19 AFS of the retransmission CM-MM radiocentres |
| 9 AFS of the DCP data collection and transmission system | 20 OTVS blend |
| 10 AFS of the retranslation and transmission DM-radiocentres | 21 Magnetometer |
| 11 Array platform | 22 Thermal screen, thermal screen drive |
| | 23 Proton & electron sensor |
| | 24 Low energy particles spectrometer |

Fig. 1.

meteorological phenomena. As mentioned earlier, national ground data receiving and processing complex consist of the Main (Moscow) and regional centres (RPC's). GOSGIDROMET will operate space and ground segments of GOMS, offering the following services to various users:

- * IMAGING - GOMS will acquire images of the full Earth disk in two spectral channels (in three, beginning with GOMS N 2), up to 48 times per day. Images will be pre-processed in the Main RPC before distribution to users.
- * ANALOG IMAGE DISSEMINATION - pre-processed data will be retransmitted from the Main RPC via s/c to national and foreign user stations (SDUSS)
- * DATA COLLECTION AND RELAY - environmental data from the national and foreign DCP's will be collected and retransmitted to the RPCs and users.
- * SPACE ENVIRONMENT MONITORING - various parameters of radiation state and magnetic field of the space at the geostationary orbital altitude will be measured and relayed to the RPCs.
- * METEOROLOGICAL DATA DISSEMINATION - image fragments, charts and other meteorological data in alphanumeric form will be re-transmitted from RPCs via s/c to national and foreign users.

It is also foreseen to provide an exchange of high-speed digital data (retransmission via s/c) between the Main and Regional RPCs.

The Main RPC located in Moscow will perform extraction of meteorological products from GOMS raw spectral measurements. An integrated computer processing system has been developed for this purpose, providing primary and secondary processing of GOMS image data. Table 3 shows end products which will be generated on a routine basis by the Main RPC after launch and testing of GOMS.

General scheme for data flow between space - and ground segments of GOMS is shown in Figure 2.

CMV DERIVATION SYSTEM OUTLINE

Cloud motion winds (vectors) have been produced routinely by NOAA since mid - 1970s and by both the Japan Meteorological Agency and the European Space Agency since 1978. In the GOMS CMV derivation system the cloud motion vectors will be calculated by tracking target clouds using 30-minute time sequential images, taking into account an experience gained by the above satellite operators. The system performs specific tasks automatically and also using interactive procedures [1]. Figure 3 presents general scheme for the CMV derivation from the GOMS imagery. The following major procedures are foreseen to compute CMV values.

SPACE SYSTEM WITH GOMS

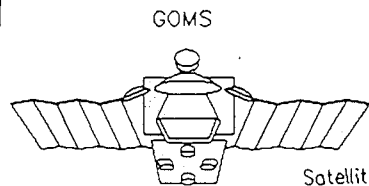
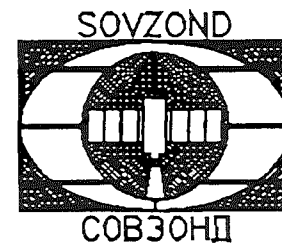

Satellite attitude control system

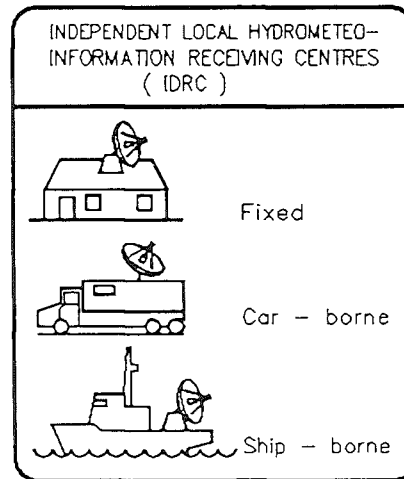
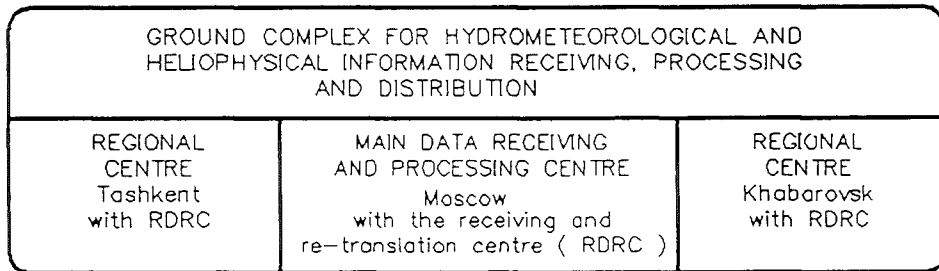
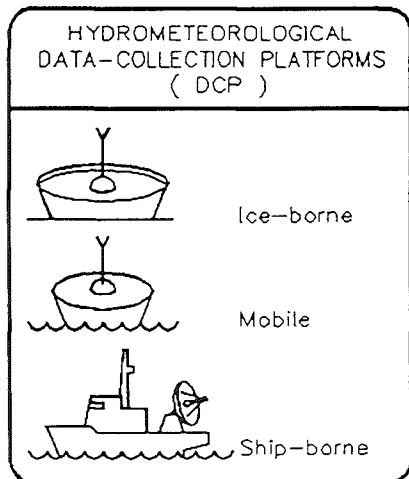
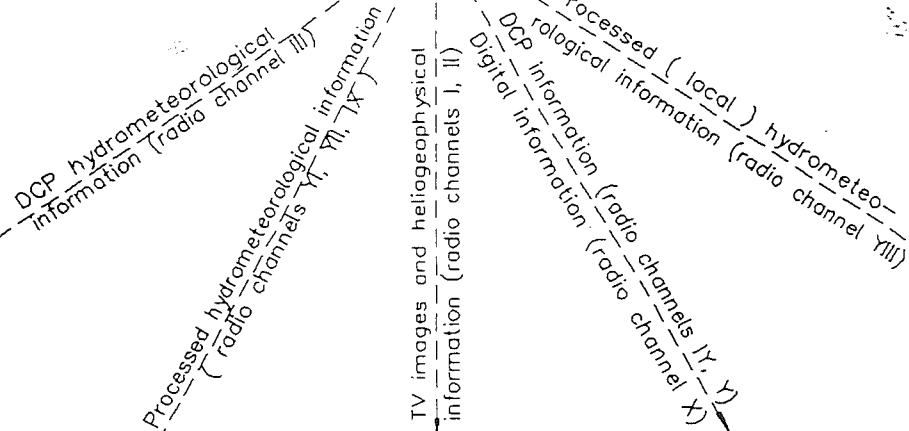
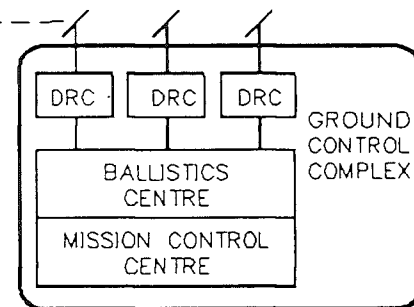

Fig. 2.

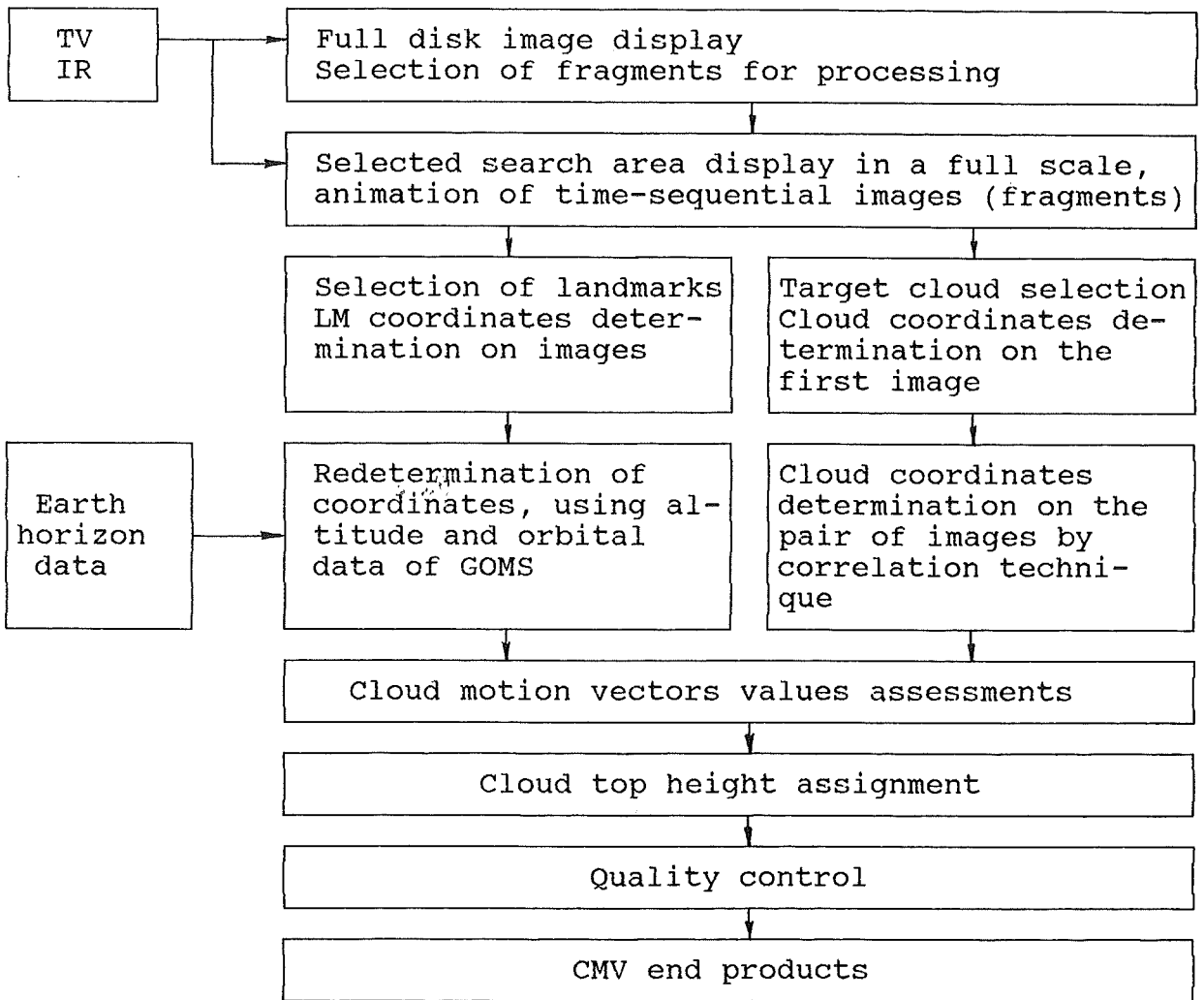

Fig.3 Flow diagram for CMV derivation.

TABLE 3. METEOROLOGICAL PARAMETERS EXTRACTED FROM GOMS MEASUREMENTS

TYPE OF PRODUCT	DESCRIPTION	COVERAGE	OUTPUT FREQUENCY	DISTRIBUTION MODE
Cloud image	IR and VIS images of cloud cover and Earth surface	Full disk	hourly	WEFAX format
Cloud motion vectors (CMV)	Wind speed and direction data at 2 or 3 levels in the troposphere, derived from 3 consecutive images	Within 50-70deg. of great arc circle from sub-satellite point	0000 GMT 1200 GMT	via domestic links and GTS (SATOB code form)
Sea - surface temperature (SST)	Values of temperature at the ocean surface derived from IR measurement	Indian ocean	0000 GMT 1200 GMT	via domestic links and GTS
Typhoon analysis	Location of typhoon centre, intensity estimates	Indian ocean	as required	GTS

* Image navigation

3 consecutive IR and one VIS images are used for target cloud selection and tracking. The predicted altitude and orbital data, scanning geometry are used to calculate the relationship between target cloud location on the image and its location on the earth. A set of landmarks is used to adjust the image to earth location. Earth horizon data are extracted from IR full disk to provide final tuning of the earth location in the image.

* Target cloud selection and tracking

An interactive procedure is foreseen where an operator first selects search area and then selects and tracks suitable target on TV - monitor where 3 pictures with 30-minute difference are displayed. Cloud coordinates determination is performed using correlation technique.

* Cloud top height assignment

CMV is assigned to the most probable cloud height estimated from the "nearest" climatological profile and an equivalent black body temperature.

* Quality control

Filtering procedure is foreseen to remove unrepresentative winds in the resultant vectors array. Some vectors are removed automatically using threshold values of matching surface, CTHs, wind acceleration, others by an analyst in interactive mode.

* CMV end product output

The final data will be plotted in a CMV - chart and will be available in the local computer network. CMVs also are coded into WMO SATOB code form for subsequent teletype domestic transmissions as well as to worldwide users over the Global Telecommunication System of WMO. It is also foreseen to archive CMV values in the form of magnetic tape.

ACKNOWLEDGMENT

The author wishes to express his appreciation to Dr. Yu. Trifonov for providing technical information and useful comments. The author also thanks Dr. L. Anekeeva and I. Solovjeva for contribution of material for the preparation of this paper.

REFERENCES

1. Anekeeva L.A., Karpov A.V. and Solovjeva I.S., 1989: Processing algorithm and technology for wind derivation from geostationary satellites, Trudy GOSNITSIPR, Vyp. 33, Seria B, Leningrad, Gidrometeoizdat, p.79-84.
2. Karpov A. 1991: Hydrometeorological, Oceanographic and Earth-resources satellite systems operated by the USSR, Adv. Space Res. Vol.11, N 3 pp. (3) 183 - (3) 190.
3. Report of the nineteenth meeting of the Coordination Group for Meteorological Satellites (CGMS-XIX), Tashkent, USSR, 10-14 December 1990.